



Safety Investigation Report

ACCIDENT TO CESSNA F152 AT LOMMEL ON 09 JUNE 2011

TABLE OF CONTENTS

FOREWORD	4
SYMBOLS AND ABBREVIATIONS	5
SYNOPSIS	6
1. FACTUAL INFORMATION	7
1.1 HISTORY OF FLIGHT.....	7
1.2 INJURIES TO PERSONS.....	9
1.3 DAMAGE TO AIRCRAFT.....	9
1.4 OTHER DAMAGE.....	10
1.5 PERSONNEL INFORMATION.....	10
1.5.1 Student pilot.....	10
1.5.2 Instructor.....	10
1.6 AIRCRAFT INFORMATION.....	11
1.6.1 General description.....	11
1.6.1 Airframe.....	13
1.6.2 Engine.....	13
1.6.3 Propeller.....	13
1.6.4 Maintenance.....	14
1.6.5 Weight and balance.....	14
1.6.6 Fuel system.....	15
1.6.7 Fuelling.....	16
1.6.8 Fuel quantity indication.....	17
1.6.9 Flight manual.....	20
1.7 METEOROLOGICAL CONDITIONS.....	22
1.8 AIDS TO NAVIGATION.....	22
1.9 COMMUNICATION.....	22
1.10 AERODROME INFORMATION.....	23
1.11 FLIGHT RECORDERS.....	26
1.12 WRECKAGE AND IMPACT INFORMATION.....	26
1.12.1 Site of the accident.....	26
1.12.2 Condition of aircraft wreckage.....	28
1.13 MEDICAL AND PATHOLOGICAL INFORMATION.....	30
1.14 FIRE.....	30
1.15 SURVIVAL ASPECTS.....	30
1.16 TESTS AND RESEARCH.....	31
1.17 ORGANIZATIONAL AND MANAGEMENT INFORMATION.....	31
1.17.1 Registered Facility Aero Club Keiheuvel.....	31
1.17.2 Rules of Procedure Aero Club.....	32
1.17.3 Regulations.....	32
1.18 ADDITIONAL INFORMATION.....	33
2. ANALYSIS	34
2.1 LAST FLIGHT.....	34
2.1.1 FLIGHT PREPARATION.....	34
2.1.2 PRE-FLIGHT INSPECTION AT EBKH.....	34
2.1.3 FUEL MANAGEMENT IN FLIGHT.....	34
2.1.4 EMERGENCY LANDING.....	35
2.2 FUEL USAGE AND ENDURANCE.....	36

AAIU-2011-17

2.3	FUEL RECORDS	37
2.4	FUEL QUANTITY INDICATION.....	37
3.	CONCLUSIONS.....	38
3.1	FINDINGS.....	38
3.2	CAUSES.	38
3.3	CONTRIBUTING FACTORS.	38
4.	SAFETY RECOMMENDATIONS.....	38
4.1	RECOMMENDATION 2011-P-13.....	38
5.	ENCLOSURES.....	39
5.1	ENCLOSURE 1.....	39

FOREWORD

This report is a technical document that reflects the views of the investigation team on the circumstances that led to the accident.

In accordance with Annex 13 of the Convention on International Civil Aviation, it is not the purpose of aircraft accident investigation to apportion blame or liability. The sole objective of the investigation and the Final Report is the determination of the causes, and define recommendations in order to prevent future accidents and incidents.

In particular, Art. 17.3 of EU Regulation 996/2010 stipulates that a safety recommendation shall in no case create a presumption of blame or liability for an accident, serious incident or incident.

Unless otherwise indicated, recommendations in this report are addressed to the Regulatory Authorities of the State having responsibility for the matters with which the recommendation is concerned. It is for those Authorities to decide what action is taken.

The investigation was conducted by L. Blendeman, H. Metillon and S. Laureys. The report was compiled by S. Laureys.

NOTE:

For the purpose of this report, time will be indicated in UTC, unless otherwise specified.

SYMBOLS AND ABBREVIATIONS

'	Minute
°	Degree
°C	Degrees centigrade
'	Feet
"	Inch
AGL	Above Ground Level
ATC	Air Traffic Control
BCAA	Belgian Civil Aviation Authority
BHP	Brake horsepower
CAVOK	Ceiling And Visibility Okay
E	East
EASA	European Aviation Safety Agency
EBAW	Aerodrome Antwerpen/ Deurne
EBKH	Aerodrome Balen/ Keiheuvel
EBKT	Aerodrome Kortrijk/ Wevelgem
EBSG	Aerodrome Saint-Ghislain
FAA	Federal Aviation Administration
FH	Flight Hour
ft	Foot (Feet)
KIAS	Knots Indicated Airspeed
KTAS	Knots True Airspeed
lbs	Pounds
LH	Left-Hand
m	Meter(s)
METAR	Meteorological Aerodrome Report
N	North
nm	Nautical mile(s)
O/H	Overhaul
PIC	Pilot In Command
POH	Pilot's Operating Handbook
QFU	Magnetic bearing of the runway
QNH	Pressure setting to indicate elevation above mean sea level
RH	Right-Hand
RPM	Revolutions per Minute
RWY	Runway
SEP	Single Engine Piston rating
S	South
SL	Sea Level
US Gal	US Gallon
UTC	Universal Time Coordinated
V	Volt
VZW	Vereniging zonder Winstoogmerk (Association without lucrative purpose)
W	West

SYNOPSIS

Date and hour: 09 June 2011 at 16:00 UTC

Aircraft: Cessna F152

Accident location: In a field in the industrial area of Lommel
(N 051° 11.715' - E 005° 15.263')

Aircraft owner: Aeroclub Keiheuvel

Type of flight: Cross-country training flight

Phase: Landing

Persons on board: 2

Abstract:

After a cross-country training flight with 3 take-offs and 2 landings, the pilot entered the circuit to make the final landing at the home base, EBKH. Not long after turning into the base leg, the student notified the instructor that the engine was losing power. After some confusion, the instructor took over control when already in final. Approx at 650 ft AGL, they both agreed that they were too low and too slow to reach the runway. There was a heavy upwind and they feared to touch the trees standing in the line of the runway. After looking around, the instructor decided to turn towards an open area with wind behind. They touched the ground for a first time before the first ditch and tried to pull the aircraft back up. Probably, the nose landing gear suffered some impact damage during this manoeuvre. After crossing the first ditch and the road, the nose landing gear broke when entering the second ditch bordering the road. The engine ploughed into the ground and the plane flipped over.

The two pilots untightened themselves and climbed out of the airplane. The instructor warned the rescue services.

Cause(s):

The cause of the accident was fuel exhaustion leading to a loss of engine power.

Hazard identified during the investigation ¹:

Performing an incomplete pre-flight inspection leading to an inadequate evaluation of the fuel on board.

Consequence ²:

Fuel starvation (FUEL)

¹ Hazard – Condition or object with the potential of causing injuries to personnel, damage to equipment or structures, loss of material, or reduction of ability to perform a prescribed function.

² Consequence – Potential outcome(s) of the hazard

1. Factual information.

1.1 History of flight.

This was going to be the first long visual navigation flight of the student pilot, as preparation for the cross-country flight of 150 nm, which is required to obtain a JAR-FCL pilot private license. He prepared the flight with the tracks indicated on an aeronautical chart and the flight times calculated by deduced reckoning, using the forecasted wind velocity of 240°/9 kts. The plan was to make 2 stops and to fly from EBKH to EBKT, from EBKT to EBSG and from EBSG to EBKH, a total flight of approx. 202 nm. See simulated flight track on Figure 1.

The student pilot arrived at about 13:00 local time at the airfield and first checked oil and fuel. The latter was done by looking at the fuel quantity indicators in the cockpit. The fuel gauge indicated 2 full fuel tanks (72 lbs each). After pulling the aircraft out of the hangar on the concrete surface in front of the aerodrome fuel pump, he completed a pre-flight check. He was told by his instructor to pay extra attention because the aircraft has had 200hr maintenance the day before and this was the first flight. During this walk around, he noticed that 3 camlocks of the upper engine cowling were loose. He went after a screw driver and tightened them.

In meanwhile, the instructor had arrived. The student pilot told him that he performed a pre-flight check and that both tanks were filled up. After a second quick check together, they started the engine and began to taxi at about 13:30 local time. Right after the take-off, at approx. 100 ft AGL, 3 camlocks of the upper cowling popped out. There was still enough runway in front of them, so they decided to put the aircraft back on the ground. They tightened the camlocks and let the engine run at 2500 RPM for 30 seconds to check for any abnormalities. The popping out of the camlocks was a known problem and already notified in the past to the mechanics. They took off again.

They first flew +- 60 minutes from EBKH to EBKT where they did a full stop for 30 minutes. The instructor made a call to EBSG to check if that airfield was open after which they started the engine and took off. The student pilot had some difficulties to locate the airfield because he first mistook the airfield of Amougies for that of Saint-Ghislain. At EBSG, they did a full stop for 40 minutes and both took a coffee. Both the student and the instructor performed a walk around check of the aircraft before leaving EBSG back to EBKH. The student declared that the both fuel quantity indicators pointed to just below half tanks. Having backwind to Keiheuvel, they concluded that there was enough fuel left for the last flight. Before take off, the student was told to give some extra throttle to chase away the birds which were on the runway.

During the flight to EBKH, they flew over the aerodrome of EBST. The flight of approx. one hour at 1500 ft cruise altitude amsl passed uneventfully until they arrived in the airfield circuit. Abeam threshold in downwind leg, the student pilot set carburettor heater on, flaps on 10° and engine on approx. 2100 RPM. When turning into the base leg, he selected the flaps to 20° and reduced the throttle and speed. Shortly after this action, he noticed that the RPM fluctuated for only a few seconds. The RPM at that time was 1600, what should be a normal value according to the instructor. When chatting, the engine started to cough again. At this time, the instructor took over and moved the throttle forward. The RPM went up a moment but then seriously reduced. The instructor repeated the action of moving throttle back and forth but always with the same outcome. Finally the engine stopped. At that moment, they were already in final leg at about 650 ft AGL, but according to the instructor the aircraft was too low and too slow to reach the runway. There was an heavy upwind and they feared to touch ground too early, considering a tree line crossing the flight path of the runway. For that reason, the

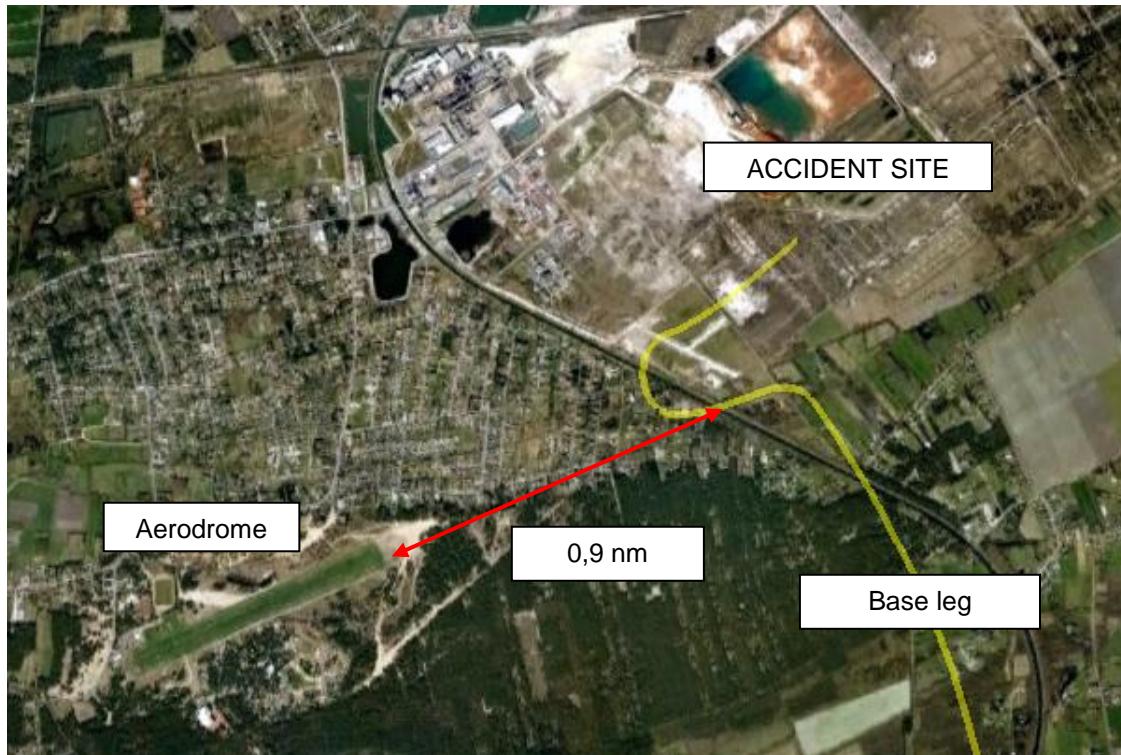

Figure 2

1.2 Injuries to persons.

Injuries	Pilot	Passenger	Others	Total
Fatal	0	0	0	0
Serious	0	0	0	0
Minor	1	0	0	1
None	1	0	0	1
Total	2	0	0	2

1.3 Damage to aircraft.

The aircraft was damaged beyond repair



Figure 3

1.4 Other damage.

There was no other significant damage.

1.5 Personnel information.

1.5.1 Student pilot

Sex: Male
Age: 38 years old
Nationality: Belgian
Licence: Student Pilot License issued on 18 February 2009. Valid until 18 February 2014.

Medical Certificate: Class 2 Certificate Issued on 30 December 2010. This certificate is valid until 22 January 2015.

Experience: 75:50 total FH of which 40:56 FH on C152
39:47 FH in the last 6 months, all on C152

1.5.2 Instructor

Sex: Male
Age: 31 years old
Nationality: Belgian
Licence: Commercial Pilot License, first issued on 28 March 2007. Valid until 28 March 2012.

Ratings:
SEP(Land) valid until 28 February 2013.
BE90/99/100/200 valid until 20 June 2012
PC12 valid until 31 December 2012

IR(A) valid until 31 May 2012

FI(A) valid until 31 July 2012

Medical Certificate: Class 1 Certificate Issued on 13 November 2008.
This certificate is valid until 29 November 2011.

Experience: More than 450 total FH on SEP(A) of which more
than 330 FH as PIC.
On C152: more than 32 FH.

1.6 Aircraft information.

1.6.1 General description.

The Cessna 152 is an all-metal high-wing two seat aircraft widely used as a trainer. It was introduced in 1978 as a successor of the popular 150. The great majority of 152s were built at the Cessna factory in Wichita, Kansas. A number of aircraft were also built by Reims Aviation of France and given the designation F152/FA152. The 152 strongly resembles its predecessor but has some significant changes. The Continental 80 octane engine was replaced by a 100 octane Lycoming O-235-L2C and the propeller was replaced by a McCauley-design. This gives the 152 a bit more power than the 150. Production was ended in 1985. The F152 is approved by FAA under Type Certificate No. A13EU.

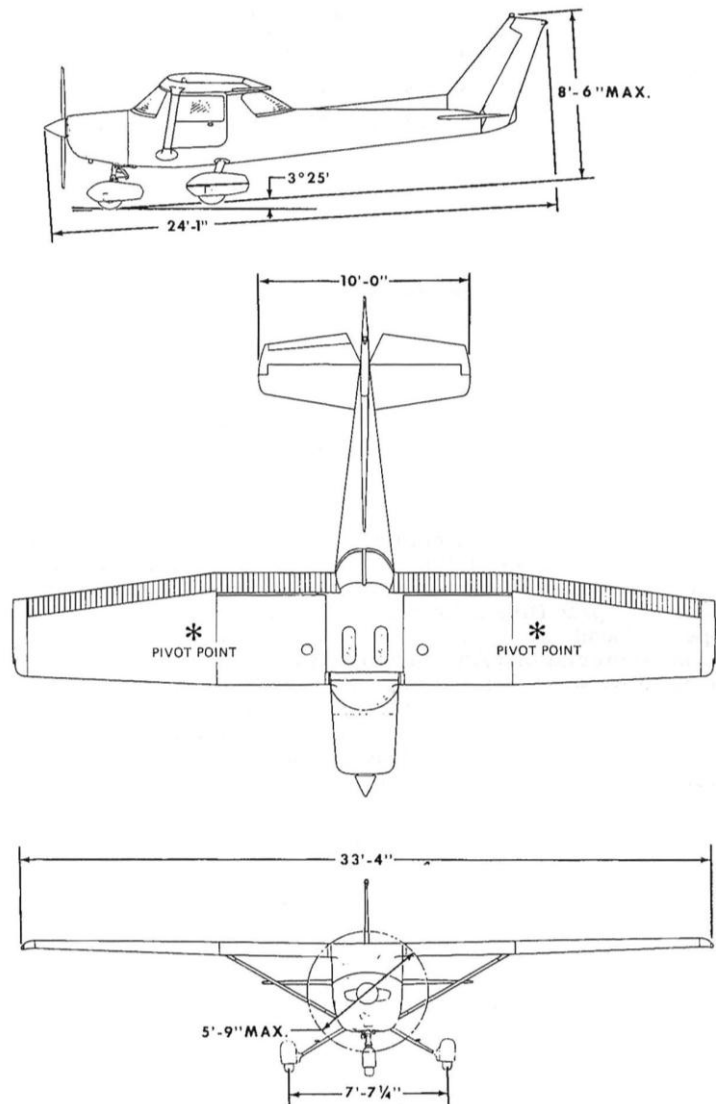

Characteristics:

Crew:	2
Length:	7,34 m
Height:	2,59 m
Wingspan:	10,16 m
Wing area:	14,86 m ²
Standard Empty Weight:	490 kg
Max take-off weight:	758 kg
Fuel:	two tanks of 13 US gallons (49l) each – Avgas

Performance (from the 'Pilot's Operating Handbook'):

Maximum speed V _{NO} :	111 KIAS
Cruise speed V _C :	107 KIAS, 75% power at 8000'
Stall speed V _S :	40 KIAS
Cruising range:	350 nm, 75% power at 8000'
Service ceiling:	14,700 ft
Fuel consumption:	23 l/h (6,1 US gallon) at 75% power at 2000'

1.6.1 Airframe.

Designer	Cessna Aircraft Company
Manufacturer:	Reims Aviation
Type:	Cessna F152
Serial number:	F15201514
Built year:	1978
Total flight hours:	9198:00 hours
Owner:	Aeroclub Keiheuvel, VZW
Certificate of Registration:	N°2959, issued on February 12, 1978 by the BCAA
Certificate of Airworthiness:	EASA form 25 issued on September 3, 2009 by the BCAA
Airworthiness Review Certificate:	issued on September 2, 2010 by the BCAA, valid until September 2, 2011.

1.6.2 Engine.

Manufacturer:	Lycoming
Type:	O-235-L2C
Serial number:	L-18156-15
Total flight hours:	8507:19 hours
Total flight hours since O/H:	1434:13 hours
Engine O/H date:	06/2005

1.6.3 Propeller

Manufacturer:	Mc Cauley
Model:	1A103/TCM6958
Serial number:	R771528
Type:	Metal, fixed pitch
Total flight hours:	9109:04
Total flight hours since O/H:	1434:13

1.6.4 Maintenance

Maintenance in the past was done by the workshop of the club, Workshop K.A-C.K approved part M subpart F Maintenance Organization BE/MF/014.

The fuel gauge of the right fuel tank was installed on 28 June 2010, the fuel gage of the left fuel tank was installed on 26 July 2010 both as per service bulletin SEB 91-7R1.

Last 200hrs maintenance was done on 7 June 2011 by Styl Aviation, an approved part M subpart F Maintenance Organization with reference number BE/MF/011. There were no remarkable findings. The engineer declared that the fuel quantity gauges indicated 'a bit' less than full (F) when he did the engine run up after the maintenance.

1.6.5 Weight and balance.

The aircraft was last weighted on September 17, 2008. Total basic empty weight was 1165,5 lbs (6 QTS oil and unusable fuel included) and centre of gravity was 30,5 inches from the front face of the fire wall (= reference datum).

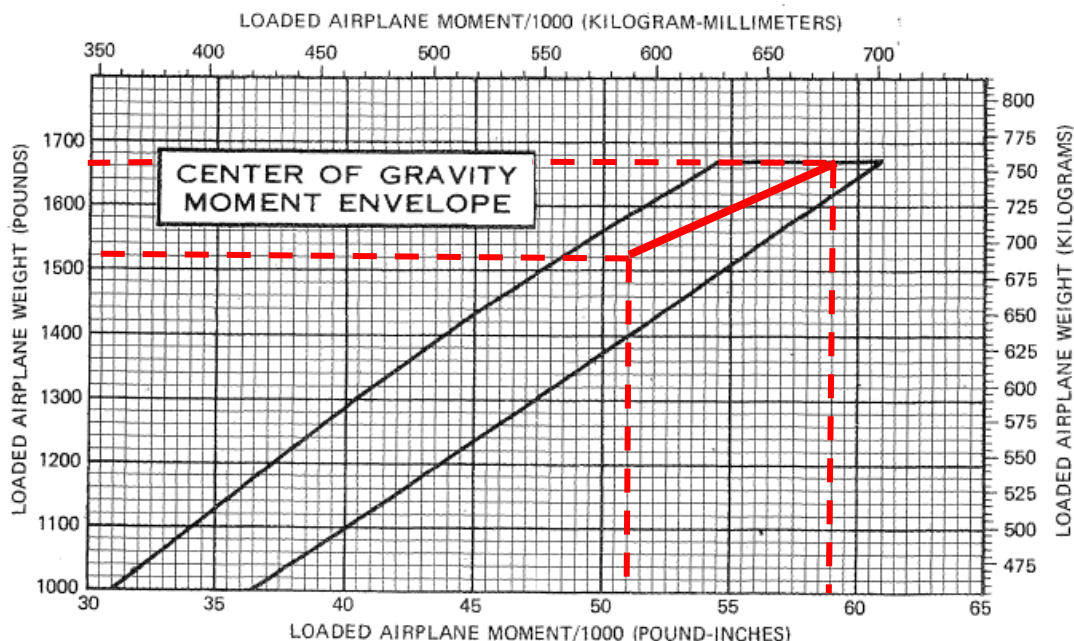

Figure 4: Center of Gravity Moment Envelope

Both with full and empty fuel tanks, the aircraft was within the limits of the center of gravity moment envelope (see Figure 4).

1.6.6 Fuel system

The aircraft is equipped with 2 standard vented aluminium tanks of 13 US Gal each, one in each wing. The system is gravity fed and both tanks supply fuel to a common line with a fuel shutoff valve which has an 'ON/OFF' selection. When the valve is in the ON position, fuel flows through a fuel strainer to the carburettor. Each tank has 0,75 US Gal unusable fuel what makes that the total fuel volume available for all flight conditions is 24,5 US Gal (92,73 l).

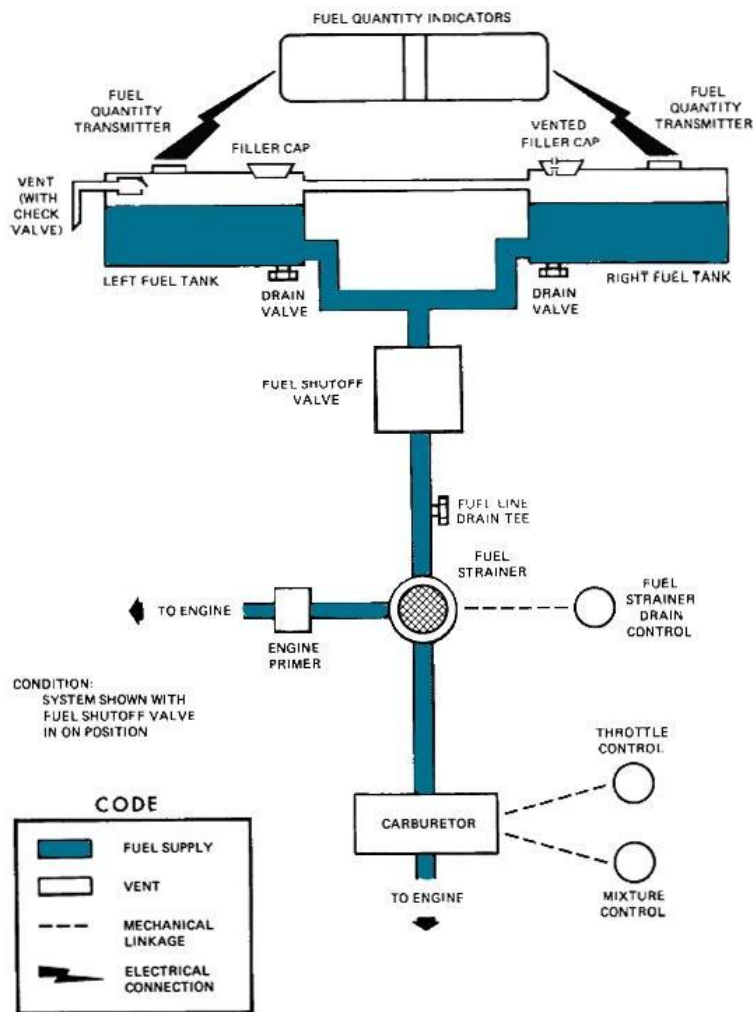

Figure 5: Fuel system

As there is no fuel pump, venting is essential to the system operation. This is accomplished by a crossover line connecting the right fuel tank with the left fuel tank. The left tank is vented via a vent tube protruding into the airstream. This tube is fitted with a check valve to prevent fuel spillage. The tank filler cap of the right tank is also vented.

As stated in the POH in section 2 on page 2-7, the tanks should be re-topped after each refuelling to assure maximum capacity due to the cross-feeding between the fuel tanks.

1.6.7 Fuelling

The airfield “refuel book”, indicated the aircraft was last refuelled with 69 l on Keiheuvel Airfield on June, 5. The PIC who performed the refuelling was contacted and he declared that the refuelling was done before his flight to EBAW. Hobbs³ time was not recorded. The tanks were both full when he took off from EBKH. He didn’t refuel before the return flight to EBKH, which was the last flight of the aircraft before the cross-country flight of the student pilot.



Figure 6: Refuel book with last refuelling of the aircraft

In all, the engine ran a little more than 5 hours between the refuelling and the accident (see Table 2).

Date	Place		Time (UTC)		Time of flight
	of departure	of destination	of departure	of arrival	
05/06/2011	EBKH	EBAW	14:33	15:20	00:47
05/06/2011	EBAW	EBKH	16:09	16:55	00:46
07/06/2011	<i>Run-up + taxi after 200hrs maintenance</i>				00:16
09/06/2011	EBKH	EBKT	11:30	12:50	01:20
09/06/2011	EBKT	EBSG	13:20	14:00	00:40
09/06/2011	EBSG	EBKH	14:43	16:00	01:17
					05:06

Table 1: Flight log since last refuelling

³ Hobbs time is the time recorded by a pressure switch that is activated by oil pressure. The meter is therefore running when the engine is running, thus also during the engine warm up and the taxiing of the aircraft.

1.6.8 Fuel quantity indication

Description

For each fuel tank, the fuel quantity is indicated in the cockpit on a moving magnet type Rochester fuel gauge, located left below the left control wheel.



Figure 7: Cockpit view with Fuel Quantity Indicators

These gauges are used in conjunction with a float-operated variable transmitter. The full position of float produces a maximum resistance through transmitter causing maximum pointer deflection 'F'. As fuel level is lowered, resistance in the transmitter is decreased, producing a smaller pointer deflection. When resistance is zero, the pointer indicates 'E' (empty).



Figure 8: Zoom on the Rochester Fuel Quantity Indicators

Some disadvantages of this system:

- As the quantity indicators are of the moving magnetic type, they can be influenced by external magnetic field changing the magnetic orientation of both the moving and the permanent return magnet;
- As the floats are installed in the forward part of the tanks and the fuel surface aligns with the gravity, they only give a correct value when the airplane is level;
- Mechanical damage to the float arm (bending) may lead to incorrect readings
- The gauges need (periodic) calibration

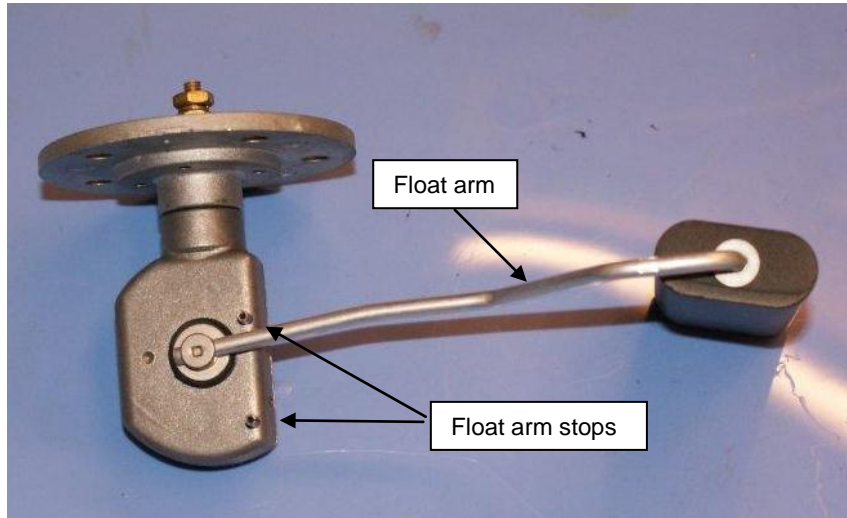

Figure 9: RH Fuel transmitter

Maintenance

Initially, the aircraft was equipped with Stewart Warner fuel indicators, P/N C669511-0101 which were developed for the Cessna 150 12V electrical system. Because the Cessna 152 series use a 28V battery, the battery sides of the fuel indicators were equipped with dropping resistors P/N 829525-6 of 75 ohms to generate a voltage drop to 12V at the input.

As Stewart Warner indicators aren't available anymore, components have to be replaced by a Rochester fuel indication system when a replacement is required or desired. Because the original Stewart Warner components aren't compatible with the replacement Rochester components, the replacement of a component requires the replacement of the entire system components. This has to be done in accordance with service bulletin SEB91-7 Revision 1.

When replacing the old fuel gauge, the dropping resistor and the steel backplate has to be removed and discarded, see wiring diagram.

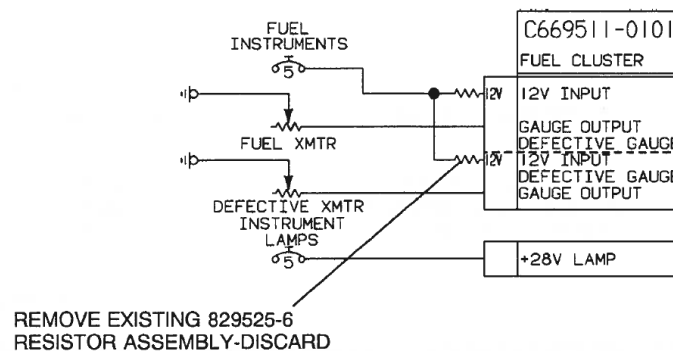

Figure 10: Wiring diagram before modification

The original service bulletin has been revised to add to following warning:

WARNING

Subsequent to the original issuance of this Service Bulletin, Cessna has become aware that the new Rochester fuel quantity gauges will indicate a greater quantity of fuel than is actually in the fuel tank if the gauge is installed on a steel backplate. If this condition exists, the fuel quantity gauge indication may appear to stay at or above the full position for a long time and then move rapidly toward lower quantity indications after a significant amount of fuel has been used. Upon reaching approximately the $\frac{1}{4}$ quantity mark on the gauge, the indicator is precise and is accurate down to the empty mark. To prevent this condition from occurring, the gauge cover and steel backplate must be replaced with those made of aluminum. Failure to replace the steel backplate can result in erroneous fuel quantity indications as described above. It is very important to remember to always physically check the fuel quantity in each fuel tank before each flight as required in the Preflight Inspection in the Pilot's Operating Handbook.

Fuel gage of the right fuel tank has been replaced on 28/06/2010, fuel gage of the left fuel tank on 26/07/2010.

1.6.9 Flight manual

The flight manual that was found in the aircraft is called the Pilot's Operating Handbook (POH) and has as part number D1107-2-13. It is applicable to the models of 1978.

Some relevant extracts:

From SECTION 3 EMERGENCY PROCEDURES

OPERATIONAL CHECKLISTS

FORCED LANDINGS

EMERGENCY LANDING WITHOUT ENGINE POWER

1. Airspeed – 65 KIAS (flaps UP).
60 KIAS (flaps DOWN).
2. Mixture – IDLE CUT-OFF.
3. Fuel Shutoff Valve – OFF.
4. Ignition Switch – OFF.
5. Wing Flaps – AS REQUIRED (30° recommended).
6. Master Switch – OFF.
7. Doors – UNLATCH PRIOR TO TOUCHDOWN.
8. Touchdown – SLIGHTLY TAIL LOW.
9. Brakes – APPLY HEAVILY.

AMPLIFIED PROCEDURES

ENGINE FAILURE

After an engine failure in flight, the best glide speed as shown in figure 3-1 should be established as quickly as possible. While gliding toward a suitable landing area, an effort should be made to identify the cause of the failure. If time permits, an engine restart should be attempted as shown in the checklist. If the engine cannot be restarted, a forced landing without power must be completed.

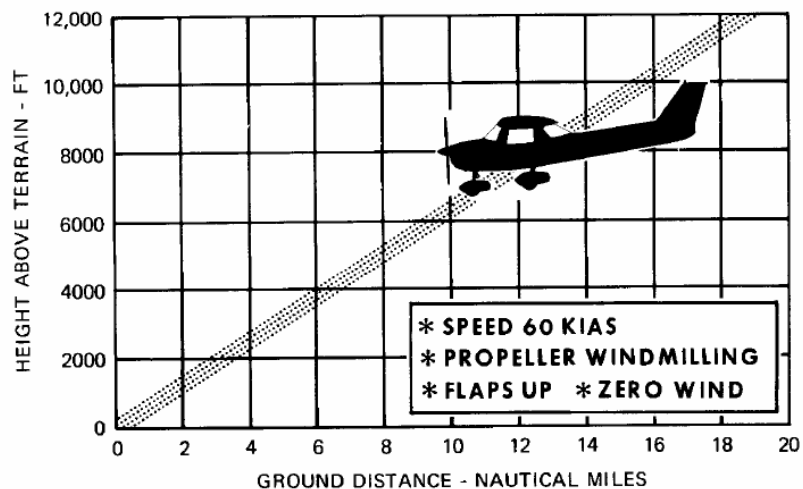

Figure 3-1. Maximum Glide

FORCED LANDINGS

If all attempts to restart the engine fail and a forced landing is imminent, select a suitable field and prepare for the landing as discussed under the Emergency Landing Without Engine Power checklist.

From SECTION 4 NORMAL PROCEDURES

CHECKLIST PROCEDURES

PREFLIGHT INSPECTION

(1) CABIN

1. Control Wheel Lock – REMOVE.
2. Ignition Switch – OFF.
3. Master Switch – ON.
4. Fuel Quantity Indicators – CHECK QUANTITY.
5. Master Switch – OFF.
6. Fuel Shutoff Valve – ON.

(4) RIGHT WING

1. Wing Tie-Down – DISCONNECT.
2. Main Wheel Tire – CHECK for proper inflation.
3. Before first flight of the day and after each refueling, use sampler cup and drain small quantity of fuel from fuel tank sump quickdrain valve to check for water, sediment, and proper fuel grade.
4. Fuel Quantity – CHECK VISUALLY for desired level.
5. Fuel Filler Cap – Secure.

(6) LEFT WING

1. Main Wheel Tire – CHECK for proper inflation.

2. Before first flight of the day and after each refueling, use sampler cup and drain small quantity of fuel from fuel tank sump quickdrain valve to check for water, sediment, and proper fuel grade.
3. Fuel Quantity – CHECK VISUALLY for desired level.
4. Fuel Filler Cap – Secure.

(7) LEFT WING Leading Edge

1. Pitot Tube Cover – REMOVE and check opening for stoppage.
2. Stall Warning Opening – CHECK for stoppage. To check the system, place a clean handkerchief over the vent opening and apply suction; a sound from the warning horn will confirm system operation.
3. Fuel Tank Vent Opening – CHECK for stoppage.
4. Wing Tie-Down – DISCONNECT.

1.7 Meteorological conditions.

The conditions were stable during the flight. The METARS at the time of the accident:

EBAW 091550Z 27011KT 230V300 CAVOK 18/02 Q1015 NOSIG=
EBBR 091550Z 25006KT 180V330 CAVOK 19/03 Q1015 NOSIG=
EBLG 091550Z 27011KT 240V300 CAVOK 18/04 Q1016 NOSIG=

This means that the wind around 10 knots was coming from approx 270° with a variation between 230° and 300°.

1.8 Aids to navigation.

The track was followed in real-time by use of an iPad with a GPS-receiver.

1.9 Communication.

Not relevant

1.10 Aerodrome information.

EBKH, Keiheuvel airfield is located in Balen (province of Antwerp) close to the border with Lommel (province of Limburg). The location served for military operations during World War II and the airfield was opened for civilian use in 1956.

Address:

Aeroclub Keiheuvel
Lichtvliegwezenlaan, 8
B - 2490 Balen

- Coordinates: 511051N - 0051315E
- Elevation: 131 ft
- Runway QFU: 067° / 247°
- Runway dimensions: 690 m x 18
- Surface: grass
- Runway strength: 5700 kg
- AFIS: "Balen Radio" - 119.200 MHz - INFO only, no ATC
- Prior notice required: 2 HRS
- Traffic circuits at 1000 ft AGL
- Mixed activity (airplanes and gliders).
- Jet aircraft operations not allowed

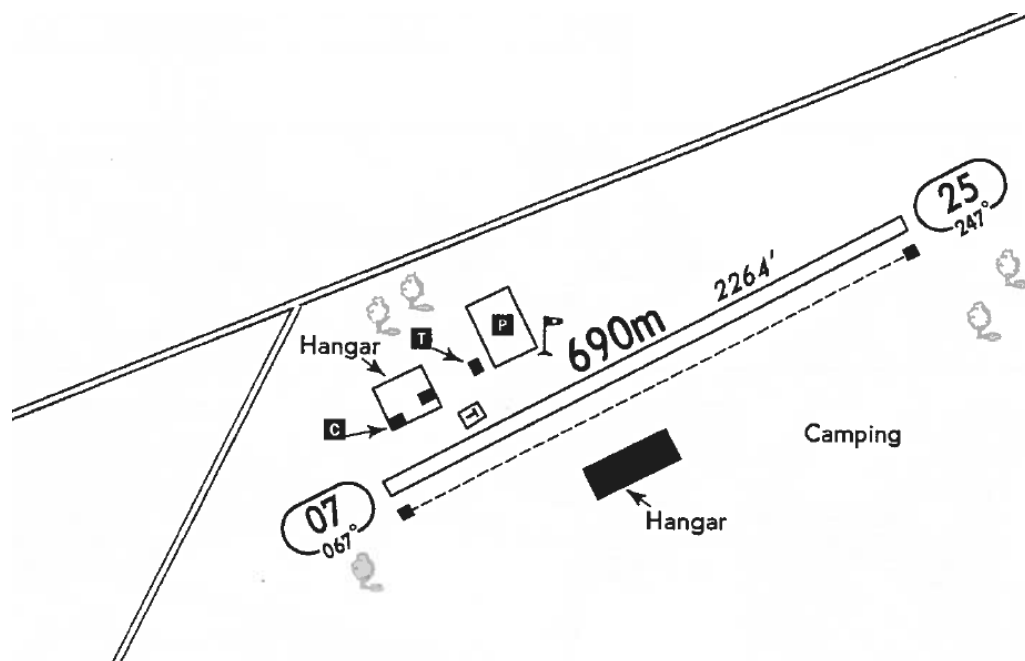

Figure 11: Aerodrome lay-out

The airfield fuel pump () is located on a flat concrete surface.

The nature reserve 'Keiheuvel' is located in front of runway 25.

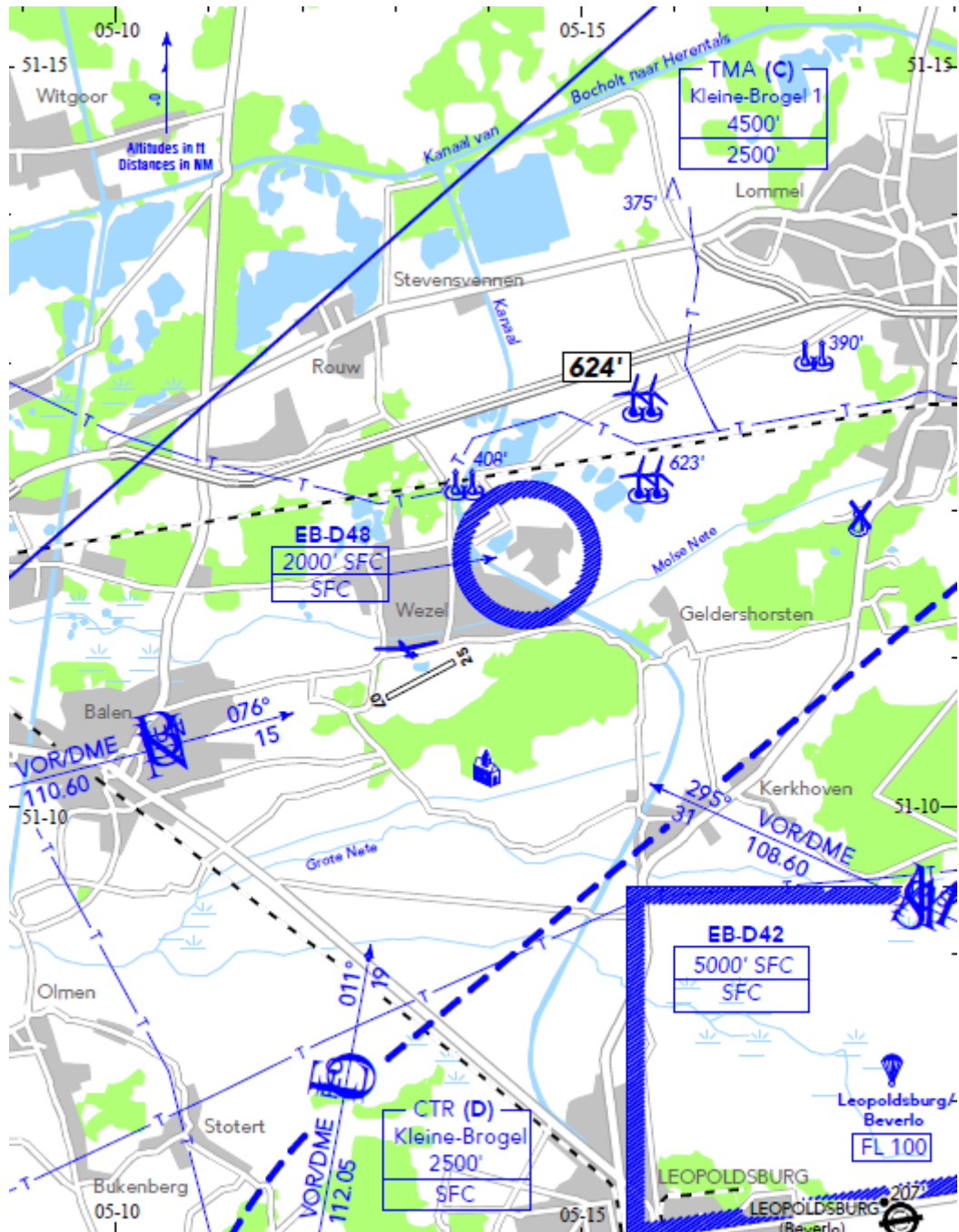

Figure 12: Location of aerodrome

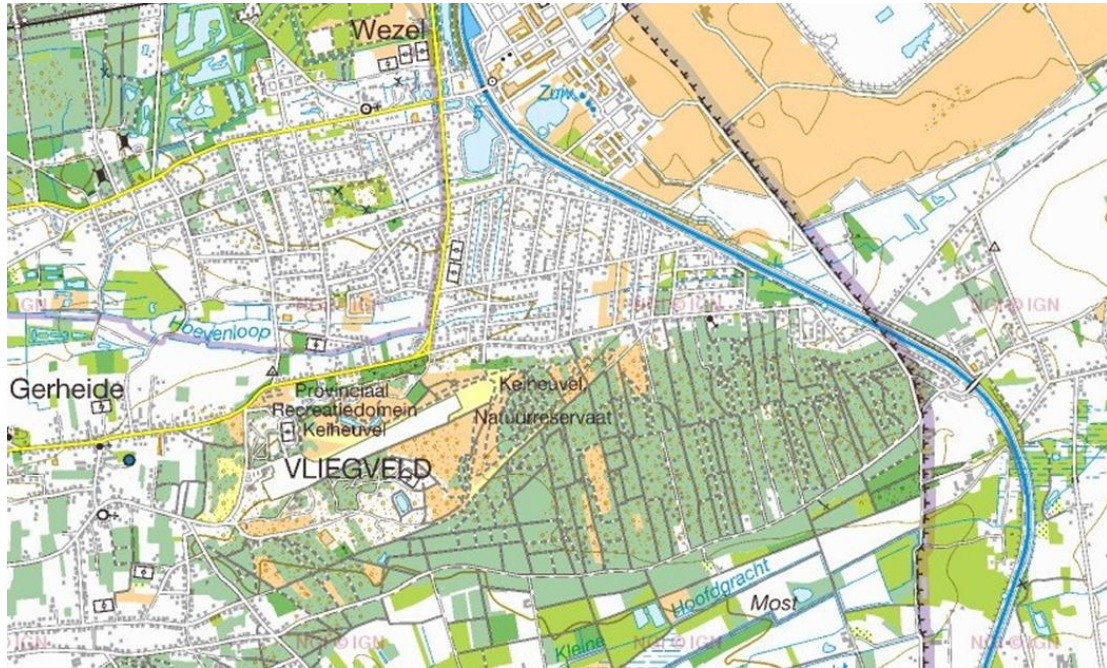

Figure 13: Circuit runway 25

1.11 Flight recorders.

No flight or voice recorders were installed or required on this aircraft, however the flight instructor had his iPad with him with Air Navigation Pro installed on it. This is a real-time aircraft navigation application with integrated flight planning using the GPS, which is also able to record the flight track. The track of the last flight from EBSG was recorded and read-out.

1.12 Wreckage and impact information.

1.12.1 Site of the accident

The aircraft crashed in a derelict field in the industrial area 'Balendijk' of Lommel (N 051° 11.715' - E 005° 15.263') approx 2,2 km from the threshold of RWY 25 of EBKH.



Figure 14: Accident site

It first touched the ground on a field, just before a road that was surrounded by 2 ditches the pilots first didn't notice. During this manoeuvre, the nose landing gear probably suffered some damage by hitting this ditch. The aircraft was slightly pulled up again to cross the road but upon entering the second ditch, the nose landing gear broke. The engine ploughed into the ground and the plane flipped over.

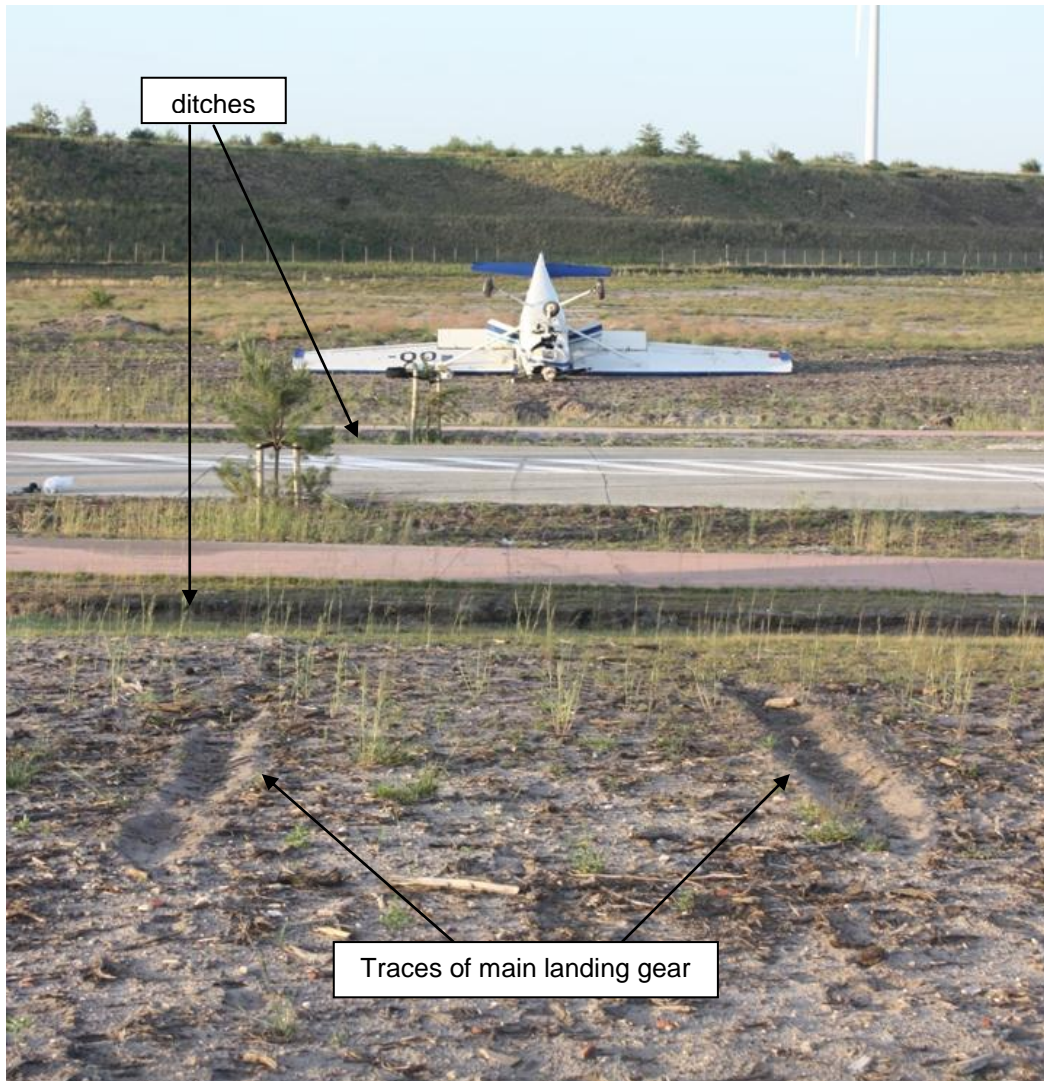

Figure 15

1.12.2 Condition of aircraft wreckage

The nose landing gear was broken by impact causing severe damage to the engine compartment with broken carburettor and fuel lines.

The windshield was exploded, the tail crushed and left wing twisted.



Figure 16: Wreckage with view on broken nose landing gear strut.

The propeller blades were only slightly damaged, confirming that the engine delivered no power during impact.



Figure 17: Propeller blades slightly damaged

The quantity of fuel remaining in the fuel tanks was assessed. The overall fuel quantity remaining in the fuel tank was estimated to be around 5l.

- the fuel tanks weren't ruptured;
- the position of the aircraft was such to retain most of the fuel inside;
- there was no strong odour of fuel felt by the police present shortly after the crash;
- a few drops fell from RH wing filler cap;
- a small quantity (2 liters) that escaped with opening of the filler caps, when levelling the wings.

The engine and fuel system were further examined on 14 June 2011.

The fuel filter was opened and inspected but no debris or other anomalies were found. The carburettor was removed and opened. Due to the impact and the turnover of the aircraft, no fuel could be found in the float chamber. Nevertheless, the chamber was free of damage and debris. The throttle valve was difficult to move but this was because the valve shaft was damaged by impact. The nozzle was removed but no blockage was found.

The rocker valve cover of one cylinder was removed to check the movement of the crank- and camshaft. When rotating the propeller blades, it could be seen that the in- and outlet valves moved up and down, showing that the shafts were still intact and connected.

Per cylinder a spark plug was removed. All 8 spark plugs were replaced during the 200hr maintenance prior to the accident flight. On two plugs, traces of combustion deposit were found. On one of them this was severe deposit of carbon/lead residue. A mechanic said that this could be due to deposit still present on the inside of the cylinder head, not removed during the maintenance.



Figure 18: Spark plug with combustion deposit

The ignition system was tested by connecting one spark plug of each cylinder to the mass. When rotating the propeller blades, high-voltage sparks could be obviously seen in the right firing order.

1.13 Medical and pathological information

Only the student was slightly injured at the face due to splinters of the busted windshield flying around. After the wound was sutured, he could leave the hospital.

1.14 Fire.

There was no fire.

1.15 Survival aspects.

The pilots both were wearing the shoulder harness during the impact. The student pilot suffered a light injury due to the splinters of the busted windshield, which could no be avoided.

The two pilots still had full consciousness and could untighten themselves and climb out of the airplane. With his mobile phone the instructor immediately warned the rescue services, which arrived very rapidly at the scene.

1.16 Tests and research.

The fuel quantity indicators were removed from the aircraft to inspect their working. During the removal it was found that a dropping resistor was installed on both gauge inputs, although it had to be discarded as per SEB91-7 Revision 1 (see paragraph 1.6.9).

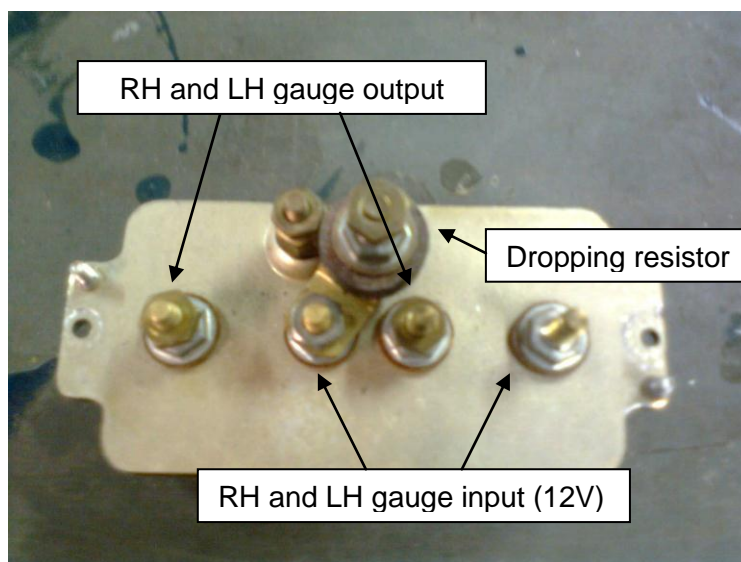

Figure 19: Backplate of fuel gauge

The fuel gauges were tested with and without the dropping resistors installed. In both cases, the deflection of the needle was the same with the same voltage applied. Only when placing the dropping resistors on the gauge outputs, the deflection was different. The pointer always indicated the maximum, independent of the applied voltage.

1.17 Organizational and management information.

1.17.1 Registered Facility Aero Club Keiheuvel

Aero Club Keiheuvel is a Registered Facility accepted by BCAA for compliance with the King's Order of 4 March 2008, and the Joint Aviation Requirements JAR-FCL 1.

The registration with reference B/RF-005 was first done on 5 February 2001 and last revised on 16 November 2010.

It offers both ground and flight instruction for PPL(A) with class ratings SEP and TMG.

The RF has made a syllabus for the practical training. This document has a paragraph dedicated to navigation in which is stated that fuel has to be calculated to reach destination, an alternate aerodrome, holding and in addition 45 minutes of reserve fuel (See enclosure 1).

1.17.2 Rules of Procedure Aero Club

The Aero Club has a 'Rules of Procedure'-document. Paragraph 6.3 describes there refuelling policy.

6.3. Tanken.
6.3.1. Veiligheid.
6.3.1.1. De veiligheidsvoorschriften hieromtrent worden strikt gevolgd. Zie paragraaf 4.
6.3.1.2. De benzinepomp wordt altijd na het tanken terug met een hangslot gesloten.

6.3.2. Tanken van clubtoestellen.
Bij het tanken wordt het tankboek volledig ingevuld: ook de stand van de urenteller van het vliegtuig dient genoteerd.

In English:

6.3.2. Refuelling of club aircraft

When refuelling, the refuel book has to be fully completed: the time on the hobbs meter of the aircraft should also be noted.

1.17.3 Regulations

The Belgian Royal Decree of 9 January 2005 laid down the procedures for the technical exploitation of aircraft belonging to general aviation, in other words, aircraft not used for commercial air transport.

A relevant extract:

Section VIII
Fuel and oil supply

Art 19. A flight is only initiated when, taking into account the meteorological conditions and the anticipated delay of the flight, the airplane carries a supply of fuel and lubricating oil sufficient to safely perform this flight and if, depending the case, following specific provisions are observed.

These provisions mentioned are only applicable for flights performed under instrument flight rules. For these flights there has to be enough fuel to reach the destination field and to fly after that for 45 minutes more.

No such obligation for VFR flight is stated in this Royal Decree.

1.18 Additional information

The aircraft's battery was fitted in a box mounted on the right forward side of the firewall. Due to the crash landing, leading to the aircraft to flip over, this box was separated from the firewall and its cover opened. Because the battery was upside down, acid was leaking when rescue workers and accident investigators arrived at the scene. This situation contained 2 risks:

- establishment of a short-circuit leading to a fire
- causing burn marks to people



Figure 20: Loose battery

2. Analysis.

2.1 Last flight

2.1.1 Flight preparation

The student pilot prepared his flight and calculated the expected flight time with the forecasted wind speed. Total flight time was calculated to be 2 hours and 4 minutes. However the calculated track begins and ends at reference point West, which is 7,2 nm from EBKH. Adding a calculated total flight time of 10 minutes for twice this leg and 45 minutes of reserve fuel as asked in the aeroclub training manual, this brings the total flight time to 3 hours. When using a safe fuel flow value of 6,6 gallon/hour (or 25 l/hour) this means that the aircraft should at least had 19,8 gallons on board.

2.1.2 Pre-flight inspection at EBKH

The fuel quantity was only checked by looking on the fuel quantity indicators inside the cabine. This was done at the fuel stand which is flat. However, the checklist procedures of the POH also ask to check visually both tanks. According to the statement of both concerned, this was done neither by the student nor by the instructor.

The student believed that the aircraft was refuelled just before the flight. According to him the fuel quantity gauges indicated full tanks. The instructor couldn't confirm this. In reality, the aircraft had already 1 hour and 45 minutes flown since last refuelling (flight EBKH-EBAW-EBKH). If we take the safe fuel flow value of 6,6 gal/h again, this means that the aircraft must have burned already 11,55 gallons of fuel and the fuel gauges would have indicated a fuel amount around a total of 14,45 gallon or 7,2 gallon per tank on board. However as one can notice on Figure 8, the fuel indicators are not-linear. This fact together with a notorious inaccuracy could have led to a faulty impression of (nearly) full tanks when departing at EBKH.

2.1.3 Fuel management in flight

According to both the student and the instructor, each leg of the flight was timed and compared with the calculated results. In EBSG the total flight time was 2 hours, although the calculated flight time on beforehand was only 1 hour and 15 minutes.

When leaving in EBSG, after 2 hours flight, the fuel quantity indicators pointed to just below half tanks (+- 6 U.S. gallon each tank left) according to the student. The instructor couldn't confirm this. However with this information and the fact that they had backwind to Keiheuvel, he and the student concluded that there was enough fuel left for the last flight.

Relying on these indicators and believing that tanks were full in EBKH, this would mean that the aircraft already burned 14 U.S.gallon or 7 gal/h. Judging by the POH and based on experience by Operator, this is not a abnormal value. In fact, most operators use a value of 6.6 gal/h or 25 l/h to calculate their endurance.

So only based on the fuel flow of the past flight time indicated by the fuel gauges, it couldn't be concluded at that time that these gauges were not reliable.

However, considering

- the deviation between the calculated and the current flight time;
- the indicated fuel already burned;
- the fact that the training syllabus of the aeroclub prescribes 45 minutes of reserve fuel;

refuelling in EBSG would have been more than justified.

2.1.4 Emergency landing

The engine stopped delivering power in final leg at about 650 ft AGL and 0,9 nm in front of the runway threshold. Because there was an heavy upwind and they feared to touch the trees standing in the line of the runway, the instructor decided to turn the aircraft with wind behind and to perform an emergency landing in the neighbourhood.

The maximum glide distance is showed in the figure of the POH below.. We can see that the altitude needed to reach a distance of 0,9 nm is approx. 600 ft. However this is only valid under the condition that flaps are up and there's zero wind. In this case flaps were already selected to 20° and there was an upwind between 5 to 11 knots. The aircraft would never have reached the runway and the instructor took the right decision to choose another landing area.

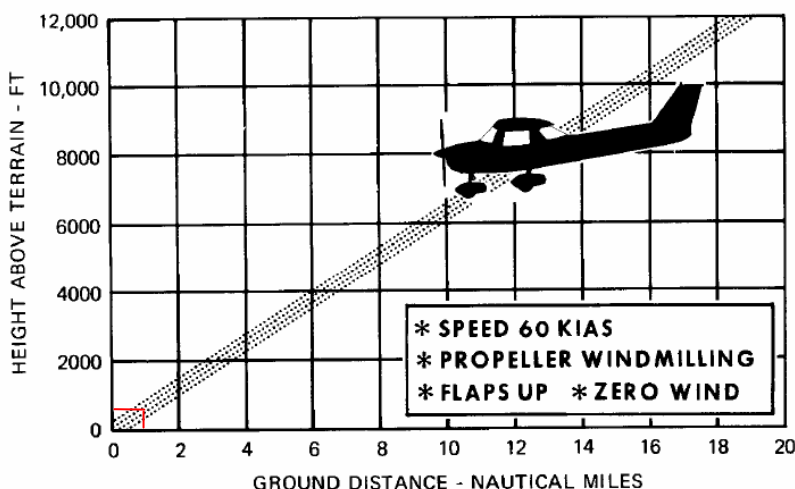

Figure 21: Maximum glide

2.2 Fuel usage and endurance

For a cruise RPM of 2200 in approx. standard conditions (QNH was 1018, temperature 18°) the BHP is around 60% and fuel flow is 4,8 gallon/hour according to the POH. If we look at the endurance profile of the POH estimating that the mean value of the BHP is between 65 and 55%, the endurance with 45 minutes fuel reserve left will be between 4 hours and 4 hours 40 minutes. The engine stopped running after 5 hours and 5 minutes, which is between those margins if you subtract the fuel reserve of 45 minutes. If we divide a total amount of fuel of 24,5 U.S. gallon by the total flight time, the result gives exactly 4,8 gallon/hour

ENDURANCE PROFILE 45 MINUTES RESERVE 24.5 GALLONS USABLE FUEL

CONDITIONS:
1670 Pounds
Recommended Lean Mixture for Cruise
Standard Temperature

NOTES:

1. This chart allows for the fuel used for engine start, taxi, takeoff and climb, and the time during climb as shown in figure 5-6.
2. Reserve fuel is based on 45 minutes at 45% BHP and is 2.8 gallons.

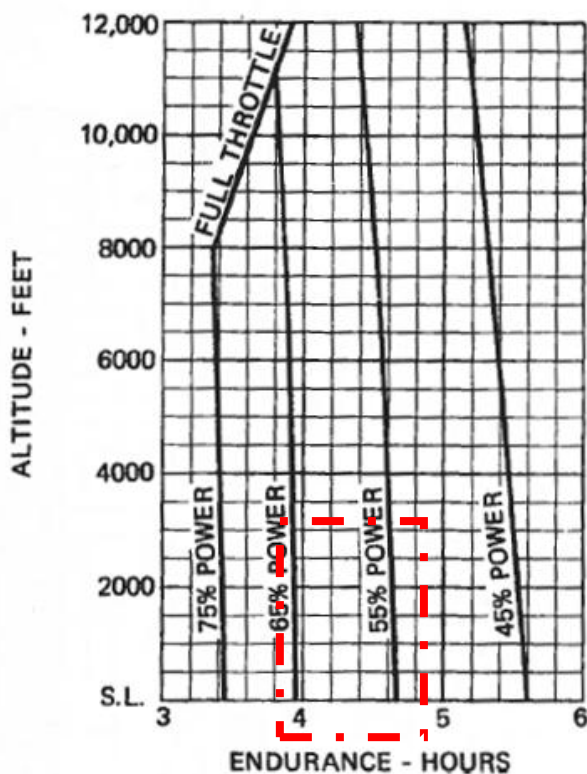

2.3 Fuel records

The last refuelling on the airfield was not completely logged in the refuel book of the aeroclub, as required by the Aero Club Rules of Procedure; the hours on the hobbs meter were not recorded.

2.4 Fuel quantity indication

The test of the fuel quantity indicators didn't show any anomaly. Due to the crash landing, the good installation of the transmitters could not be verified.

It is generally known that the fuel quantity indicators are not reliable and that they are calibrated to only give a representative value in a straight level unaccelerated flight.

SEB 91-7, states that

“a greater quantity of fuel than is actually in the fuel tank will be indicated if the gauge is installed on a steel backplate. If this condition exists, the fuel quantity gauge indication may appear to stay at or above the full position for a long time and then move rapidly toward lower quantity indications after a significant amount of fuel has been used. Upon reaching approximately the $\frac{1}{4}$ quantity mark on the gauge, the indicator is precise and is accurate down to the empty mark”.

The backplate was replaced by an aluminum one. However one cannot exclude that other metal parts didn't induce the same phenomenon.

3. Conclusions.

3.1 Findings.

- Both the student pilot and the instructor held a valid Private Pilot License.
- The airplane was in airworthy condition.
- The airplane was regularly maintained in a BCAA approved Part M Subpart F maintenance organization.
- By not inspecting visually the fuel tanks, the pre-flight inspection was not completely performed and fuel quantity was not correctly evaluated.
- The hours on the Hobbs meter were not recorded when performing the last refuelling.
- There is no requirement in Belgian Air Law to take reserve fuel with VFR flights.
- There was no calibrated dip stick inside the airplane.
- The use of a dip stick to check the fuel level was not a standard practice in the aeoroclub.

3.2 Causes.

The cause of the accident was fuel exhaustion leading to a loss of engine power. This fuel exhaustion was due to starting the flight with insufficient fuel on board.

3.3 Contributing factors.

- Not performing a completely pre-flight inspection leading to an inadequate evaluation of the fuel on board.
- Fuel quantity indicators notoriously unreliable.

4. Safety recommendations.

4.1 Recommendation 2011-P-13

AAIU (Be) recommends Aeroclub Keiheuvel to provide itself with a calibrated dip stick for each type of aircraft to visually check the fuel level and to teach at student pilots and encourage all club members the use of it.

5. Enclosures.

5.1 Enclosure 1: extract of syllabus practical training

Aeroclub Keiheuvel

18.A NAVIGATIE

DOEL: Het leren voorbereiden en uitvoeren van een navigatievlucht, steeds bewust van de eigen positie en de nog te vliegen tracks.

18.A.1 AIRMENSHIP:

Een goede vluchtvoorbereiding is het halve werk daarom is het goed te werken volgens een vast systeem:

1. Stel u op de hoogte van het laatste weer .
2. Verzekert u van de juiste en bijgewerkte luchtvaartkaarten.
3. Plan een route met korte trajecten tussen markante punten met zo min mogelijk obstakels. Start vanaf een markant punt in de directe omgeving van het vliegveld.
4. Verdeel uw route in stukken en meet nauwkeurig de afstanden en bereken de tijdsintervallen.
5. Indien u een VFR-vlucht maakt, plan dan de aankomsttijd RUIM VÓÓR Sun-Set, zodat u in geval van vertraging aan de SunSet tijd kunt voldoen.
6. Wijzig uw route of opgegeven eindbestemming niet zonder daarvan iemand in kennis te stellen.
7. Draag altijd een horloge,
8. Bereid de voorgenomen vlucht voor, overeenkomstig de hieronder volgende checklijst:

- Navigatieplan met route, uitwijkhavens en hoogtekeuze afhankelijk van het weer, obstakels en luchtruimstructuur.
- AIP, VFR gids en Bottlang raadplegen.
- NOTAM's voor de route, de bestemming en uitwijkhaven.
- Courante navigatie-, aanvlieg- en landingskaarten (approach- en landing chart) van de bestemming en uitwijkhaven.
- Brandstofberekening voor bestemming, de uitwijkhaven en holding inclusief 45 minuten reserve,
- Weight and Balance berekening.
- ATC vliegplan, indien nodig.
- Boordpapieren (BvL, Vergunningen en Medisch attest, Journaal, Flight manual, checklist).
- Boordpapieren internationaal (verzekeringpapieren, lijst van onderscheppingsprocedures).
- Persoonlijke papieren (Paspoort, visum).
- Zwemvesten, indien nodig.
- Tweede. bril, indien nodig.
- Buitenlands geld.
- Horloge.



Air Accident Investigation Unit - (Belgium)
CCN
Rue du Progrès 80 Bte 5
1030 Brussels

Phone: +32 2 277 44 33
Fax: +32 2 277 42 60

air-acc-investigation@mobilite.fgov.be
www.mobilite.fgov.be