

Safety Investigation Report

Ref. AAIU-2016-03r1

Issue date: 10 November 2017

Status: Final

SYNOPSIS

Classification:	Incident
Date and time:	3 November 2015 – time unknown
Aircraft:	Boeing B757-236 (SF), msn 22189
Location:	In a garden, in Engis, SW of EBLG airport
Type of flight:	Commercial Air Transport – International - Cargo
Phase:	climb
Aerodrome of departure:	Brussels Airport (EBBR)
Aerodrome of destination:	Leipzig/Halle Airport (EDDP)
Persons on board:	2 pilots
Injuries:	None
Occurrence type:	SCF-PP - System/component failure or malfunction (Powerplant)

Abstract

An aircraft part was found in a privately owned garden located near to the airport of Liege, Belgium (EBLG).

The part fell down from an airplane taking off from EBBR.

Subsequent examination identified the part as a rear latch access door of the Rolls-Royce RB211-535C thrust reverser, released by a Boeing B757-236(SF) aircraft during a flight from EBBR to EDDP on 3 November 2015.

FACTUAL INFORMATION

History of the event

A person living rue Nouvelle Route 185B – B4480 in Engis, Belgium found an aircraft part in his garden at the begin of April 2016 (the exact date is unknown).

After 3 weeks, he called the police, that took the part and contacted the airport of Liege, located nearby. The place where the part was found is located in the extension of runway 23L of EBLG airport, at a distance of 6 km from the end of the runway.

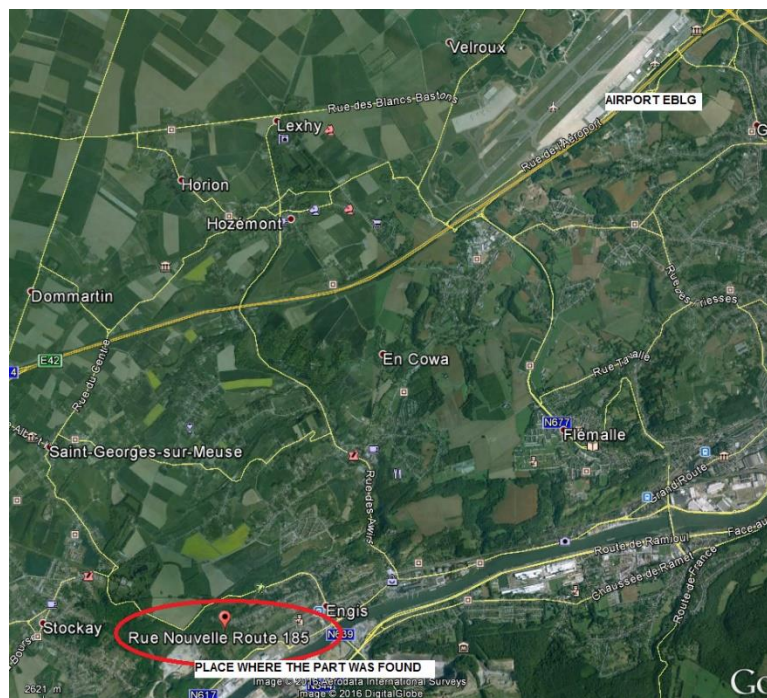

Figure 1: location of the part

The airport inspection services determined, with the help of aircraft mechanics, that the part was indeed an aircraft part coming most probably from a Rolls Royce RB211-535C engine.

The part bore the part number (P/N) LJ71687, identified as a panel from a reverser door.

The part's dimensions are 57 cm x 21 cm.

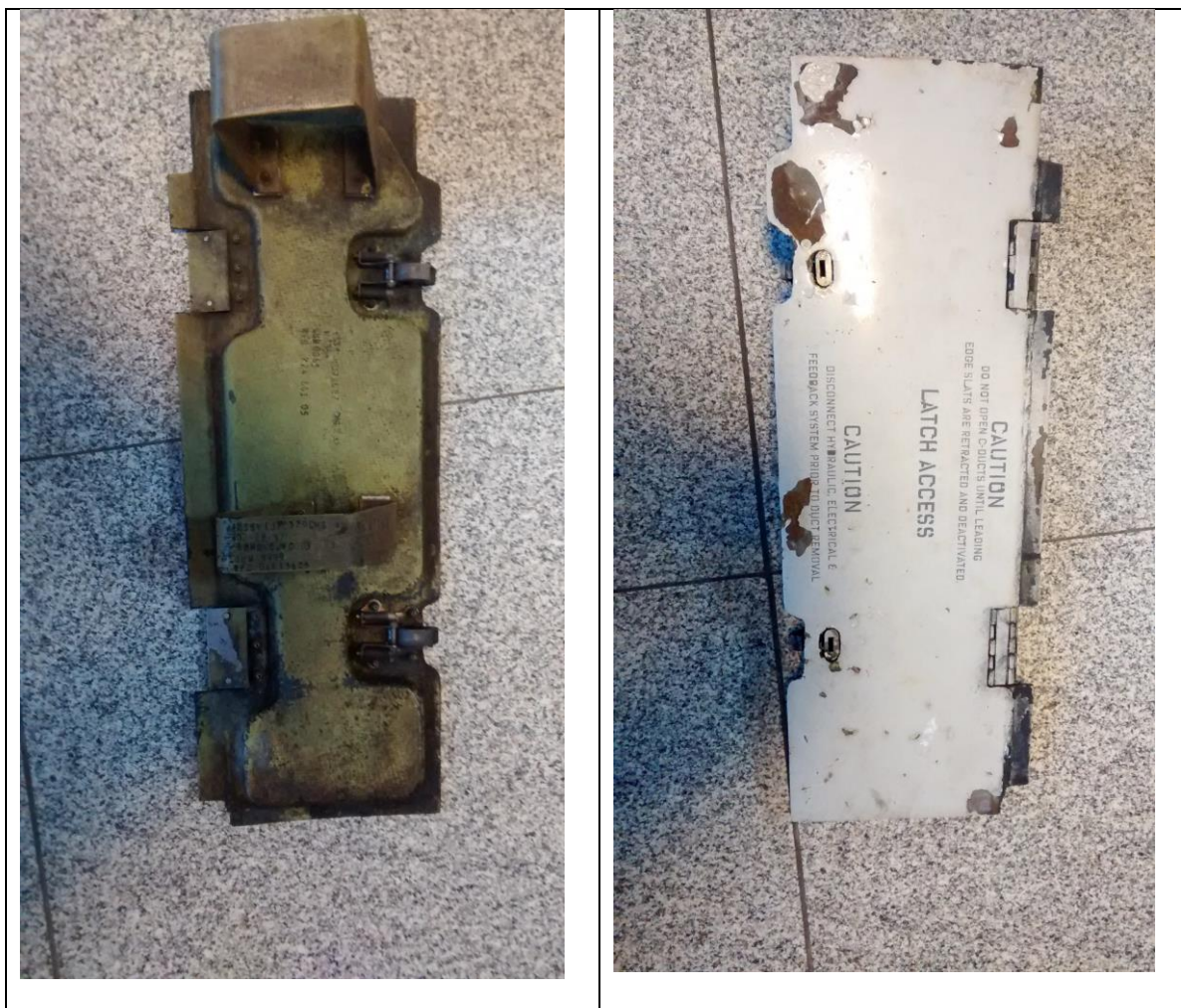

Figure 2: the fallen panel (left: interior side, right: exterior side)

The part was inspected and the part number written on the body could allow the identification of a Thrust Reverser Unit (TRU) rear latch access door (P/N: LJ71687) from a Rolls Royce RB211-535C.

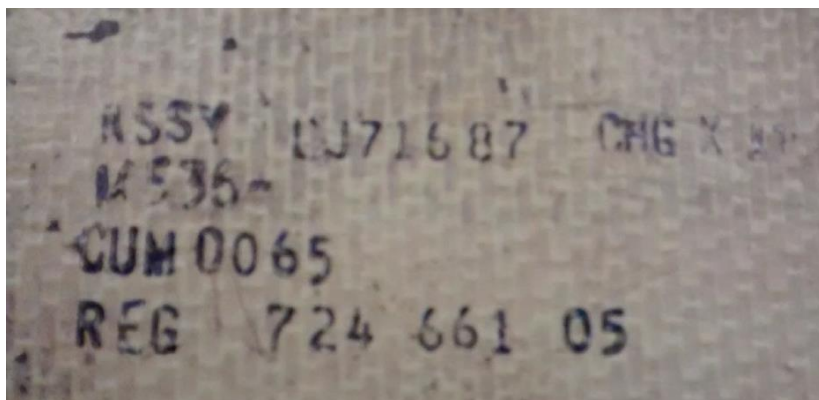

Figure 3

Investigation with Rolls Royce and the concerned operators established that the latch access door was detached from RB211-535C Engine ESN 30083 installed on the N°2 position of a B757-200 aircraft operated by DHL during a flight from EBBR to EDDP on 3 November 2015.

The aircraft records show that this part was found missing on 4 November 2015 and had to be replaced.

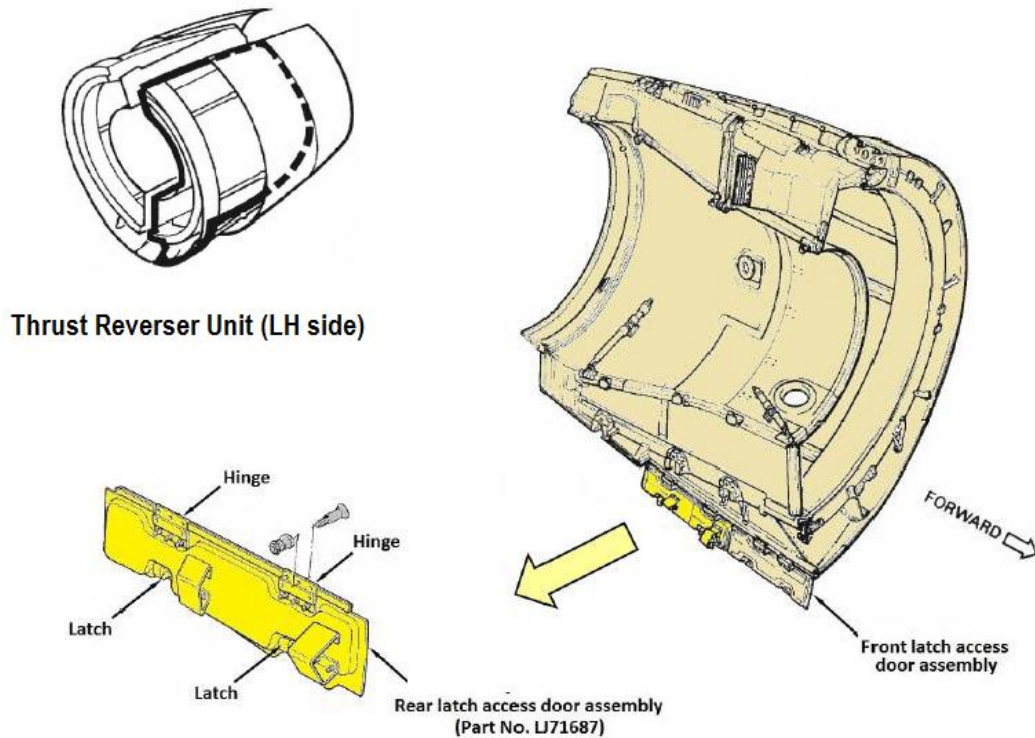

Figure 4 : Location of the latch access door when installed

The part was sent to Rolls Royce for detailed inspection.

After a thorough inspection of the part, Rolls Royce issued a report (ASI 0040 Issue 01 – dated 12/05/2017).

Aircraft information.

The Boeing 757 is a mid-size, narrow-body twin-engine jet airliner that was designed and built by Boeing Commercial Airplanes. Passenger 757-200s have been modified to special freighter (SF) specification for cargo use. Production of the 757 ended in October 2004, after 1,050 had been built for 54 customers. The 757-200 was by far the most popular model, with 913 built.

The 757-200SF, a conversion of passenger 757-200s for cargo use, entered service with DHL Aviation in 2001. Modifications by Boeing Wichita in Kansas included the removal of passenger amenities, main deck structural reinforcement, and the installation of a 757-200PF forward fuselage section with a port-side cargo door. The forward two entry doors are retained, resulting in a main deck cargo capacity of 14 pallets, which is one less than the 757-200PF. In July 2015, 173 converted 757-200SFs were in service.

Characteristics:

Length	155.25 ft (47.32 m)
Wingspan	124.83 ft (38.05 m)
Height	44.50 ft (13.56 m)
Wing Area	1,951 ft ² (181.25 m ²)
Max Takeoff Weight	255,000 lb (115,665 kg)

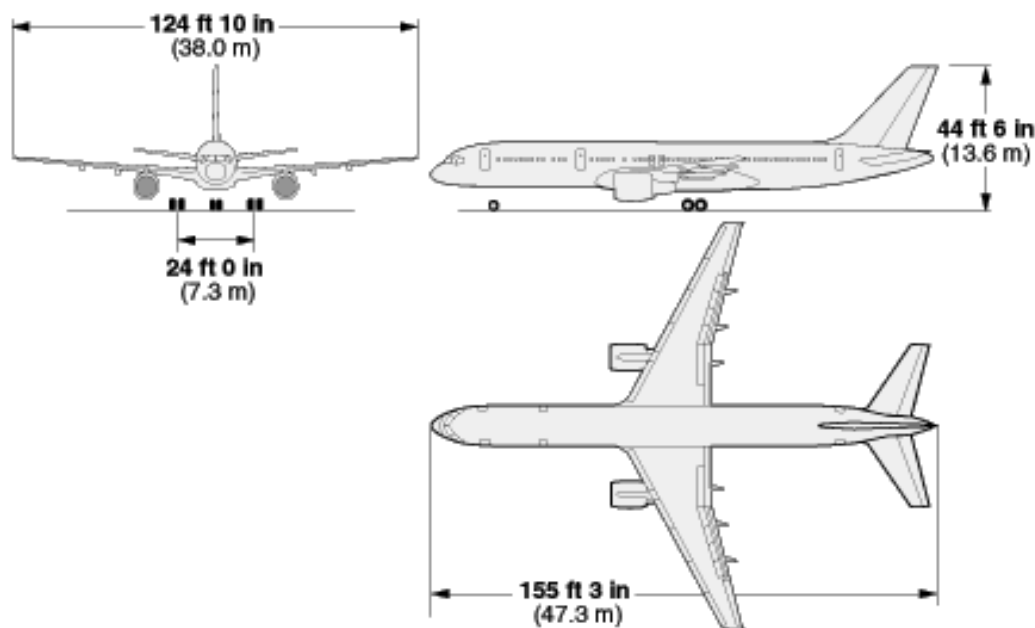

Boeing 757-200

Thrust Reverser Maintenance

The TRU latch access door is inspected on aircraft "C" check every 18 months or 6,000 hours in accordance with Boeing Maintenance Planning Document (MPD) task 78-111-00 and Aircraft Maintenance Manual (AMM) Task 78-31-00-210-806-A00. The current inspection criterion does not include a specific hinge inspection.

Risk and Classification (Survival aspects).

This event was initially categorised as a 'serious incident' which by definition means an incident involving circumstances indicating that there was a high probability of an accident and is associated with the operation of an aircraft.

The risk related to falling or flying objects is well known to construction workers working beneath scaffolds. While the objects are falling from relatively low heights, they can cause injuries ranging from minor cuts and abrasions to more serious injuries such as concussions. The risk is clearly identified and in order to reduce it, strict procedures are in place and each worker is required to wear protective equipment (helmet).

The danger (hazard) for people on the ground of falling aircraft, aircraft parts or objects is perceived by many people as high. A heavy object, released at great height, will hit the ground at a high velocity (terminal velocity) releasing an energy sufficient to cause a lot of damage, injuries to persons, or even death.

To determine the actual risk, one needs to determine the actual likelihood (probability) that this danger will cause effective harm. Very few data are available on the subject.

Determining the hazard.

The two most dramatic events involving the loss of an aircraft part are:

- The crash of a Concorde on a hotel in Gonesse, France on 25 July 2000. During the take-off roll, the aircraft rolled over a part that was released from another aircraft. This caused a tyre to burst and the subsequent rupture of fuel tanks.
- the "Bijlmerramp", accident that occurred on 4 October 1992 in the Netherlands. The engine N°3 of a Boeing B747 separated from the aeroplane and caused it to crash in an apartment building.

Besides these two tragic events, the release of objects from aircraft usually involves;

- Release of ice blocks in flight. Ice can form,
 - o naturally on aircraft flying at high altitudes which falls when the plane descends into warmer air and the ice breaks away, or
 - o from leaks from aircraft lavatory waste systems (blue ice).
Note: it can be the result of meteorological phenomena not involving any aircraft (hail).
- Release of parts from aircraft.
- Release of parts or tools left inside cavities of an aircraft (example: tools forgotten in the landing gear bay, released when the landing gear is extended).

The consequence of such event could be;

- Damage to the aircraft itself,
- Damage to ground properties,
- Injuries to persons.

Determining the likelihood

The largest objects “falling” from the sky might be aircraft themselves. Very few actually involve casualties on the ground. In Belgium, the most recent accidents to-date with ground casualties are:

- In 1997, the accident of an aerobatic aircraft in Ostend during an airshow, where the airplane fell into the crowd (9 casualties on ground)
- In 1989, the crash of a Soviet combat aircraft on a farmhouse in Kortrijk (1 casualty on ground)

The mere consequence of a part falling from aircraft is usually not as dramatic. In Belgium, during the last 20 years, an average of two events are reported per year, usually in the vicinity of an airport and so far without any regrettable consequence. In most cases, it concerns people finding an unusual object in their backyard and reporting it to the police. In some cases, the part itself does not originate from an aircraft.

The actual risk of falling aircraft parts causing injuries to persons cannot be precisely determined, but is believed to be very small and the result of:

- The frequency of parts falling off (in Belgium 2/year)
- The location where the parts are falling (the available data seem to indicate a concentration in the, usually less dense populated, vicinity of airports)
- The size and weight of the concerned aircraft part. (in average; panels and access panels are the most common parts falling from aircraft)
- The position of the part on aircraft, and the potential to cause damage to the aircraft.
- The density of population (Belgium: 363.6 people/km² – third most densely populated European member state, higher in cities), however not everybody is out in the open all the time.

This event was initially classified as ‘serious incident’.

ICAO Annex 13 and EU996/2010 defines a ‘Serious Incident’ as “an incident involving circumstances indicating that there was a high probability of an accident and is associated with the operation of an aircraft (....)”

Therefore, the classification of this event was revised from ‘serious incident’ to ‘incident’.

ANALYSIS

The initial inspection determined that the door had been released due to the break-up of the forward and rear hinges assemblies.

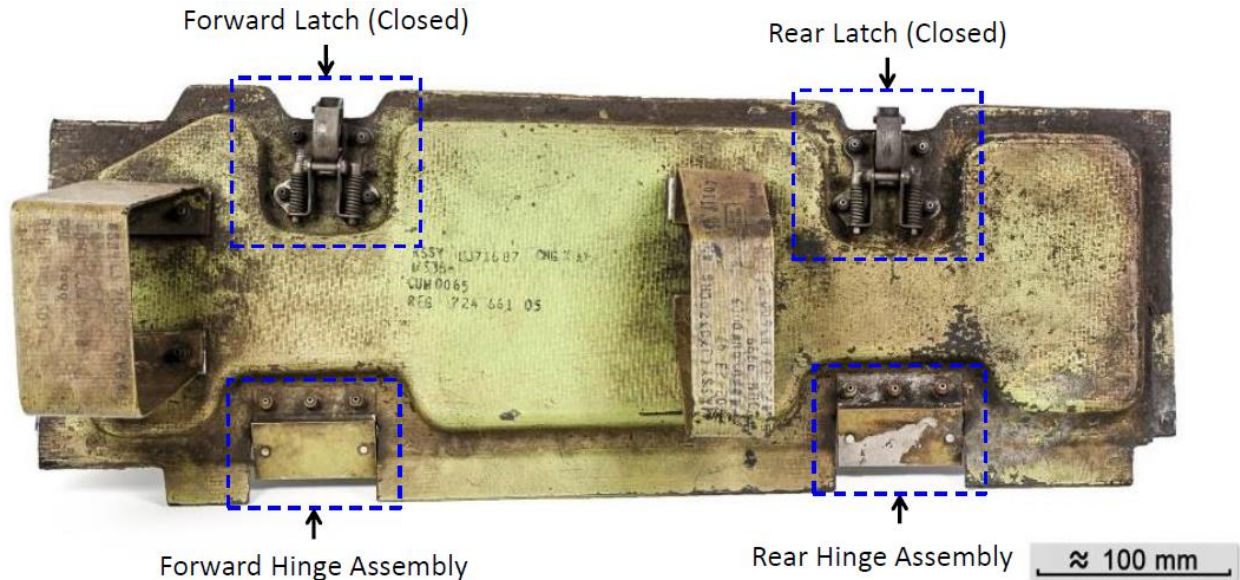

Figure 5

The inspection of the forward hinge assembly established the hinge had separated at the butt hinge pivot point on the thrust reverser side of the assembly. The respective hinge pin was completely missing with no remnants of the hinge pin left in the retaining lugs.



General view of forward hinge assembly

Close-up view showing retaining lugs (no evidence of pin remnants).

Figure 6 : Forward hinge

The inspection of the rear hinge assembly found that the hinge had separated due to complete fracture of the 2 butt hinge lugs on the thrust reverser side of the assembly.

The deformation in the fractured lugs was consistent with the access door being released at the forward hinge first and then being rotated downwards under aerodynamic loading, fracturing the lugs in overload.

Binocular examination of the fracture surfaces confirmed the lugs had fractured in overload with no evidence of propagated fracture.

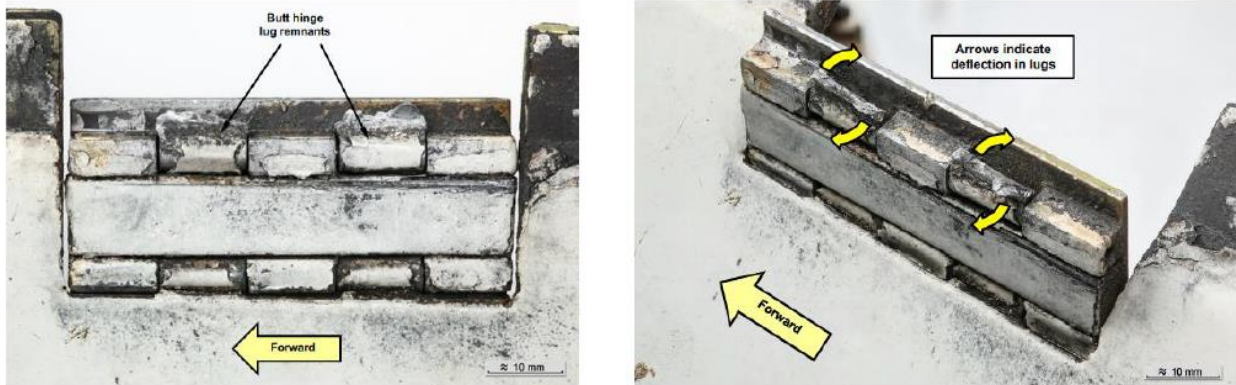

Figure 7 : Rear hinge

The examination following hinge disassembly identified some wear to the pins and lugs but this was not considered significant enough to suggest the missing pin had worn through.

A closer examination of the forward door cut-out adjacent to the missing hinge pin identified evidence that the pin had migrated forwards.

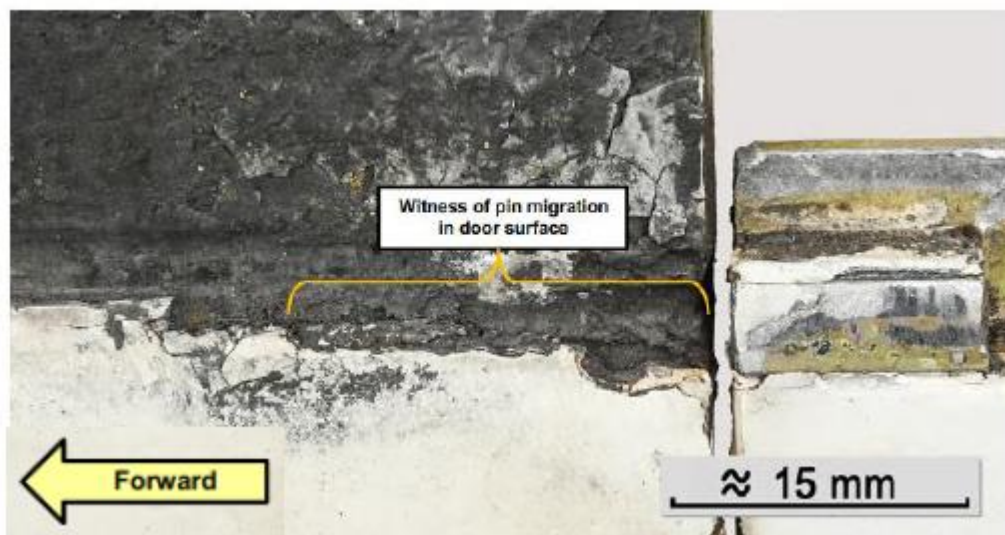

Figure 8 : Marks of migration of the forward hinge pin

This was most likely due to a combination of in-service wear and insufficient pin retention, allowing the pin to migrate forwards and disengage completely resulting in separation of the door at the forward hinge.

At all the other hinge pin locations the pins were baulked by the edges of the door cut-outs.

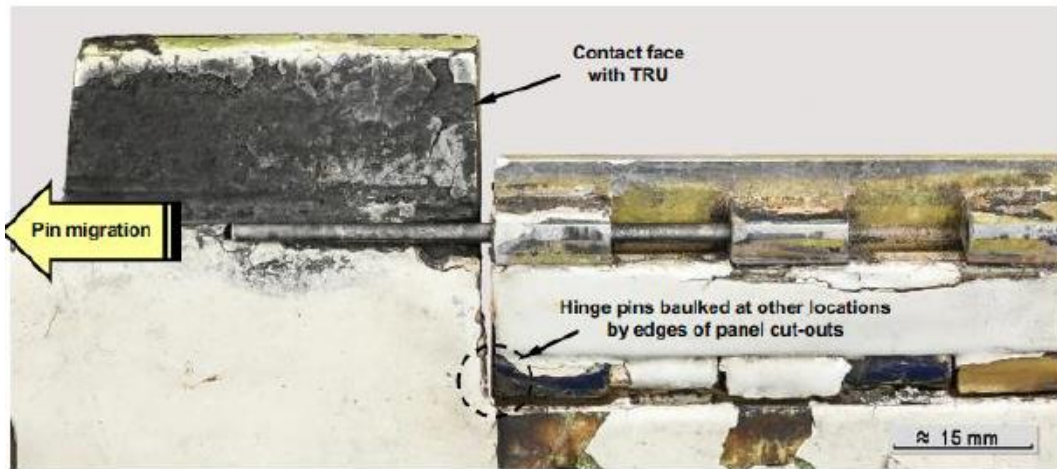

Figure 9

CONCLUSION

Cause

The release of the subject door assembly was due to separation of the forward hinge which occurred as a result of axial migration of the hinge pin on the TRU side of the hinge assembly. Migration of the hinge pin was due to a combination of in-service wear and insufficient pin retention, allowing the pin to migrate forwards and disengage completely.

Separation of the forward hinge allowed the door to dislodge into the airstream, with subsequent aerodynamic loading causing the rear hinge lugs to fracture in overload, releasing the door assembly.

Contributing factors:

The condition check of the hinges of the rear latch access door was not required by the Aircraft Maintenance Program.

SAFETY ACTIONS AND RECOMMENDATIONS

Safety actions by Rolls Royce

- Rolls Royce introduced a Request for Manual Revision (RMR) to introduce a specific wear check of the hinges into the existing AMM Task 78-31-00-210-806-A00 at next publication date (May 2017). All airframes will now be inspected to the new AMM criteria at “C” Check every 18 months or 6000 hours as per MPD task 78-111-00.
- A Rolls-Royce Safety Alert Report (SAR) has been raised to check for similar hinge designs on other Rolls-Royce engines model that could be susceptible to this issue.
- A review carried out in response of this SAR did not reveal any other TRU access door hinge arrangements that were likely to be susceptible to door release due to hinge pin / migration.
- Rolls Royce notified via Engineering Coordination Memo (ECM) Boeing and Airbus of the investigation findings to bring the issue of potential latch access door release to their attention in order to cover applications where the aircraft manufacturer holds design authority for the thrust reverser system.

AAIU(Be) supports these safety actions and has no further recommendations.

Safety actions by the operator

DHL is the only operator with RB211-535C powered B757 aircraft in service. They currently operate 17 aircraft. Based on the findings from the investigation, DHL have introduced a special inspection task to check the TRU latch access doors for hinge pin wear and migration at aircraft “A” Check. Inspection of the entire DHL operational fleet has now been completed.

About this report

The investigation was conducted by the AAIU(Be) with the support of the British AAIB and Rolls-Royce plc. This report is based upon the report issued by Rolls Royce after examination of the components (ASI 0040 Issue 01 – dated 12/05/2017).

As per Annex 13 and EU regulation EU 996/2010, each safety investigation shall be concluded with a report in a form appropriate to the type and seriousness of the accident and serious incident. For this occurrence, a limited-scope, fact-gathering investigation and analysis was conducted in order to produce a short summary report.

It is not the purpose of the Air Accident Investigation Unit to apportion blame or liability. The sole objective of the investigation and the reports produced is the determination of the causes, and, where appropriate define recommendations in order to prevent future accidents and incidents.